

Flat Pattern view
SCALE: 1:2

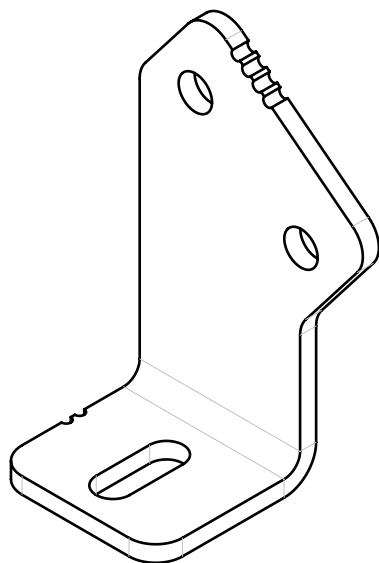
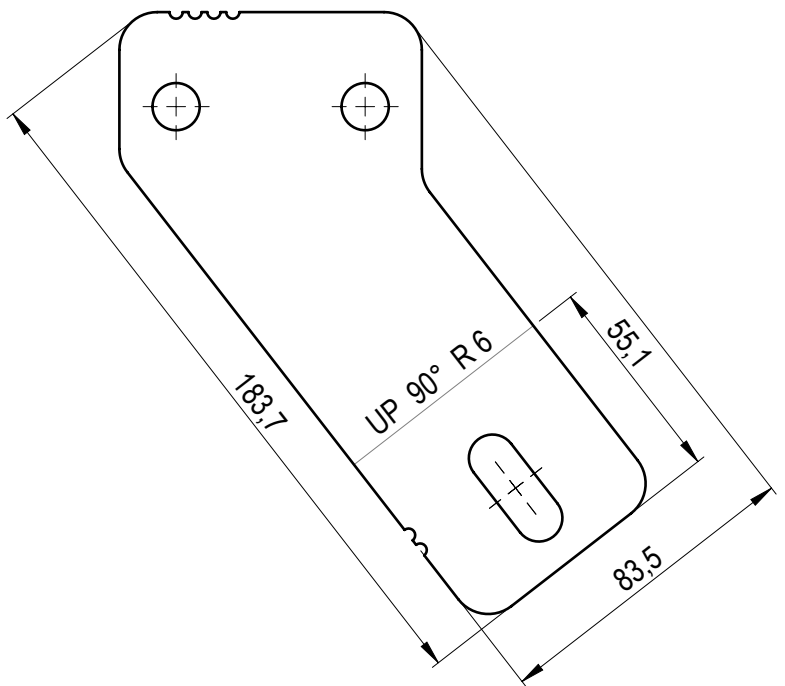

Other dimensions from .DXF file.

SHEET METAL INFORMATION	
Length, mm	183.7
Width, mm	83.5
Thickness, mm	6
Inside Bend Radius, mm	6
K-Factor	0.5
No. of Bends	1

	MATERIAL		WEIGHT	DEBURR AND BREAK SHARP EDGES		REVISION	DATE	
	S355J2		0.488 Kg	DO NOT SCALE DRAWING			28.05.2025	
SURFACE PROTECTION		MACHINING	THERMAL CUTTING	WELDING		SCALE	FORMAT	
HDG EN ISO 1461		ISO 2768 mK	ISO 9013 221	ISO 13920 BF		1:2	A4	
NAME		SIGNATURE	PART NO.					
Designed by		D. Dislers	105-09100-45					
Drawn by		D. Dislers	DESCRIPTION				SHEET 1/1	
Technical ref.			Right bracket 7L					